

# Replacement of right A-pillar inner panel assembly

## Remove

1. Remove the front wall panel assembly. Refer to
2. Use a sander to grind the sealant on the A-pillar inner panel assembly.

Maintenance method indicator	Descriptions
	Cut with disc sander, etc.

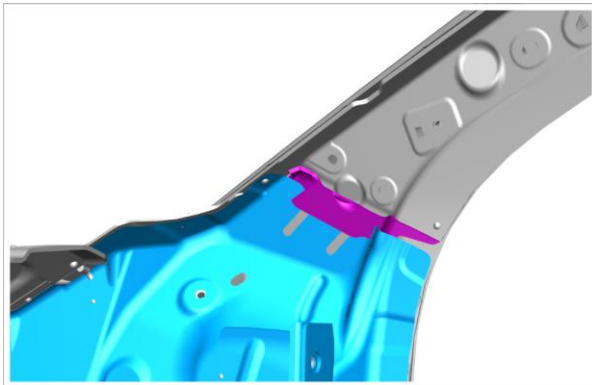

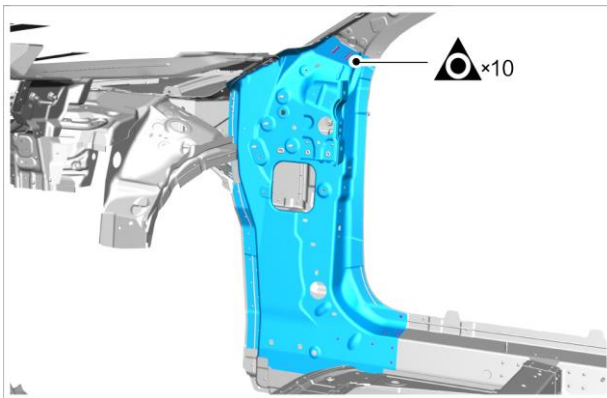

- 3.
4. Remove 10 welding spots.

Maintenance method indicator	Descriptions
	Remove the welding spots (the replaced panel is on the outer side)



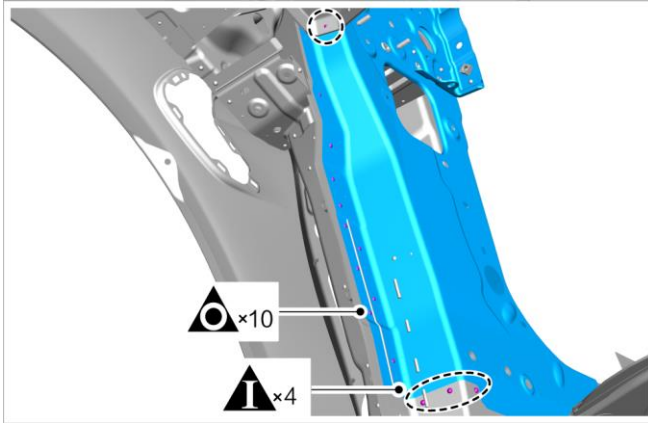

- 5.
6. Remove 14 welding spots.

Maintenance method indicator	Descriptions
	Remove the welding spots (the replaced panel is on the inner side)
	Remove the welding spots (the replaced panel is on the outer side)



- 7.
8. Remove 7 welding spots.

Maintenance method indicator	Descriptions
	Remove the welding spots (the replaced panel is on the inner side)
	Remove the welding spots (the replaced panel is on the outer side)

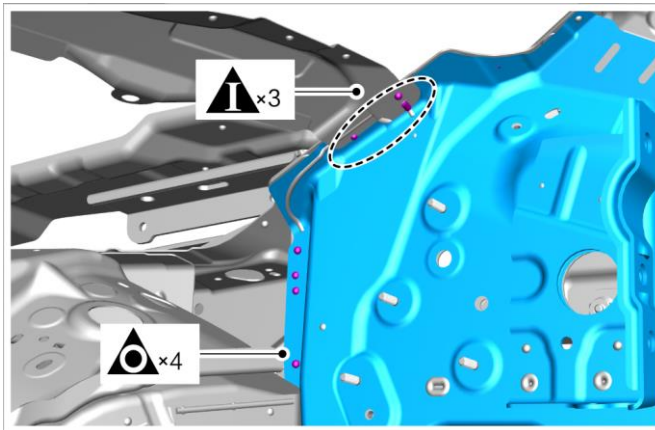

- 9.
10. Remove 18 welding spots and take out the right A-pillar inner panel assembly.

Maintenance method indicator	Descriptions
	Remove the welding spots (the replaced panel is on the inner side)

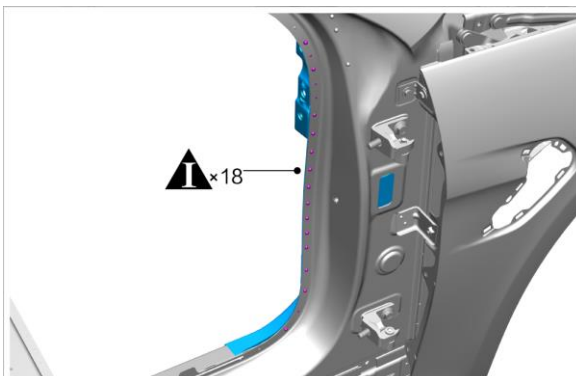

- 11.

- Remove 3 welding spots and take out the right A-pillar inner panel assembly.

Maintenance method indicator	Descriptions
	Remove the welding spots (the replaced panel is on the outer side)

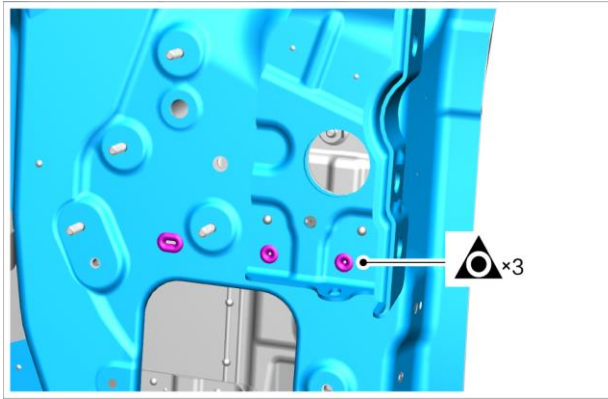

13.

## Install

- Clean the joint of right A-pillar inner panel assembly and apply adhesive.

Maintenance method indicator	Descriptions
	Body sealant

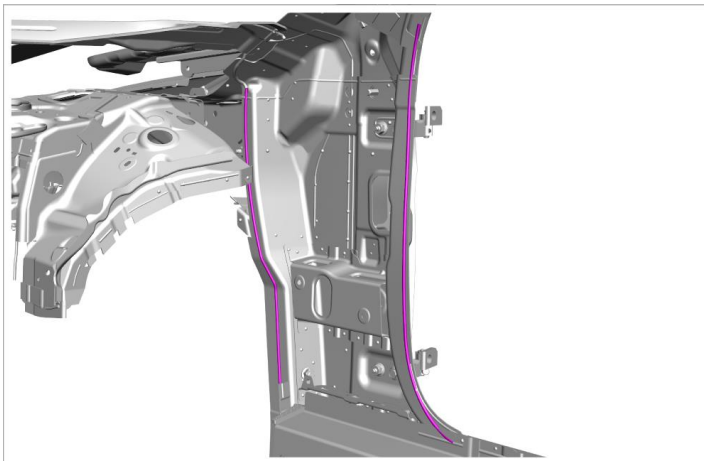

- 
- 
- Fix the right A-pillar inner panel assembly to the installation position.
- Check and adjust the relative positions and sizes of the right A-pillar inner panel assembly and the front compartment parts. Refer to
- Check and adjust the relative positions and sizes of the right A-pillar inner panel assembly and the underbody parts. Refer to
- Weld 3 welding spots on the right A-pillar inner panel assembly.

Maintenance method indicator	Descriptions
	Spot welding (the replaced panel is on the outer side)

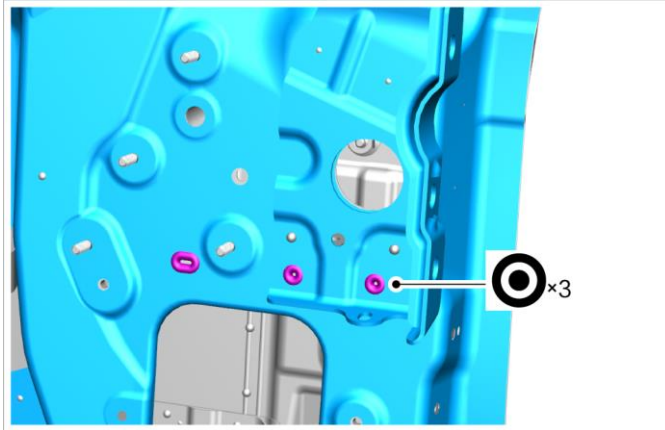

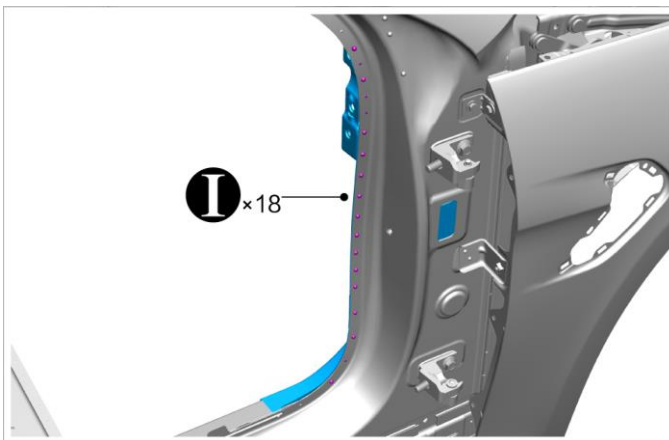

- 7.
8. Weld 18 welding spots on the right A-pillar inner panel assembly.

Maintenance method indicator	Descriptions
	Spot welding (the replaced panel is on the outer side)



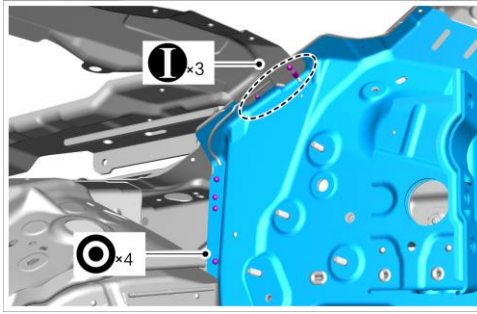

- 9.
10. Weld 7 welding spots on the right A-pillar inner panel assembly.

Maintenance method indicator	Descriptions
	Spot welding (the replaced panel is on the inner side)
	Spot welding (the replaced panel is on the outer side)



- 11.
12. Weld 14 welding spots on the right A-pillar inner panel assembly.

Maintenance method indicator	Descriptions
	Spot welding (the replaced panel is on the inner side)
	Spot welding (the replaced panel is on the outer side)

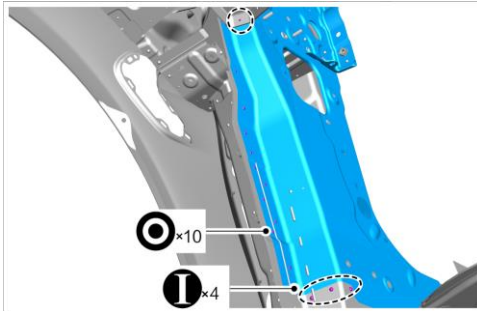

- 13.
14. Weld 10 welding spots on the right A-pillar inner panel assembly.

Maintenance method indicator	Descriptions
	Spot welding (the replaced panel is on the outer side)

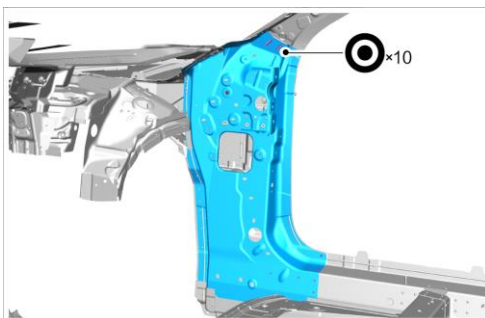

- 15.
16. After applying the external coating, apply rust inhibitor to the inner plate part of the welding spots of the closed section structure.
17. Install it in the reverse order of removal.